

USER MANUAL

ENGLISH - VERSION 1

STRADALE PROFILE

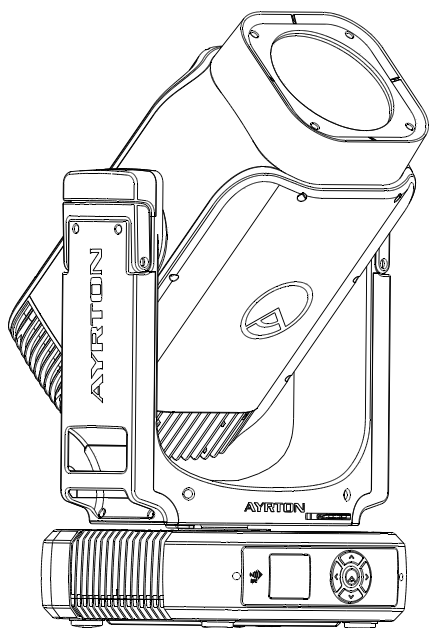

AYRTON

Digital Lighting



2 Rue de Vitruve,
91140 Villebon-sur-Yvette,
France

CONTENTS

1. SAFETY INSTRUCTIONS 3

2. FEATURES 3

3. FIXTURE OVERVIEW 4

4. DRAWINGS 4

5. INSTALLATION INSTRUCTIONS 6

6. DMX-512 CONTROL CONNECTION 7

7. DMX-512 CONNECTION WITH DMX TERMINATOR 7

8. DEVICE DMX START ADDRESS SELECTION 7

9. OPERATING INSTRUCTIONS OF THE INTERNAL DMX WIRELESS SYSTEM 7

10. DISPLAY 8

11. NFC 13

12. DMX PROTOCOL 13

13. ERROR MESSAGES 13

14. CLEANING AND MAINTENANCE 14

Keep this manual for future needs.

Errors and omissions for all information given in this user manual are possible.
All information is subject to change without prior notice.









1. SAFETY INSTRUCTIONS

1.1 > IMPORTANT SAFETY WARNINGS

This device has left the factory in perfect condition. In order to maintain this condition and to ensure safe operation, it is absolutely necessary for the user to follow the safety instructions and warning notes written in this user manual.

In order to install, operate and maintain the lighting fixture safely and correctly we suggest that the installation and operation be carried out by qualified technicians and these instructions be carefully followed.

CAUTION	
	High voltage. Risk of severe or fatal electric shock.
	Always disconnect mains supply before removing any fixture covers.
	Never look directly into the light source. Sensitive persons may suffer an epileptic shock.
	Blue light hazard: risk group 2.
	A fixture exposed to salt water should not be stored in its foam insert without being cleaned with fresh water first. It is best practice that the fixture be stored dry.
	Never touch the device during operation. Covers may be hot.

Warning: Changes or modifications to this unit not expressly approved by the party responsible for compliance could void the user's authority to operate the equipment.

Note: This equipment has been tested and found to comply with the limits for a class A digital device, pursuant to part 15 of the FCC rules. These limits are designed to provide reasonable protection against harmful interference when the equipment is operated in a commercial environment. This equipment generates, uses and can radiate radio frequency energy and, if not installed and used in accordance with the instruction manual, may cause harmful interference to radio communications. Operation of this equipment in a residential area is likely to cause harmful interference in which case the user will be required to correct the interference at his own expense.



Damage caused by the disregard of this user manual is not subject to warranty. The dealer and manufacturer will not accept liability for any resulting defects or problems.

- If the device has been exposed to temperature changes due to environmental conditions, do not power on immediately. The resulting condensation could damage the device. Leave the device powered off until it has reached room temperature.
- Ensure the sealing rubber covers of powerCON TrueOne and XLR connectors are fitted properly when the device is not in use, to avoid water ingress.

- This device falls under protection-class I. Therefore, it is essential that the device be earthed.
- If either lenses or display are damaged (damage may include cracks or gashes in the material) they must be replaced.
- Electrical connections, such as replacing the power plug, must be performed by a qualified person.
- Make sure that the available voltage is not higher than that which is stated in this manual.
- Make sure the power cord is never crushed or damaged by sharp edges. If this should be the case, replacement of the cable must be done by an authorized dealer.
- If the external flexible power cord of this device is damaged, it shall be exclusively replaced by the manufacturer or their service agent or a similar qualified person in order to avoid injury.
- When the device is not in use or before performing maintenance, always disconnect the device from the mains. Only handle the power cord from the plug. Never pull the plug out of a socket by tugging the power cord.
- When powered on for the first time, some smoke or smell may occur. This is caused by coating on metal parts when heated and is normal. If you are concerned, please contact your distributor.
- Do not focus the beam onto flammable surfaces. The minimum distance between the exiting lens of the device and the illuminated surface must be greater than 2 meters.

CAUTION

Please be aware that damage caused by any modifications to the device are not subject to warranty. Keep away from children and non-professionals.

1.2 > GENERAL GUIDELINES

- This device is a lighting effect for professional use on stages, in discotheques, theatres, etc. The device was designed for indoor and outdoor use.
- This fixture is only allowed to be operated within the maximum alternating current as stated in the technical specifications in section 2 of this manual.
- Handle the device with care avoid shaking or using force when installing or maintaining the device.
- If you use the quick lock cam when rigging the device, make sure the quick lock fasteners are located in the quick lock holes correctly and securely.
- Operate the device only after having familiarized yourself with its functions. Do not permit operation by persons not qualified for operating the device. Most damage is the result of unprofessional operation.
- Please use the original packaging if the device is to be transported.
- The applicable temperature for the device is between -20 °C to 45 °C. Do not use the device outside of this temperature range.
- The light source contained in this luminaire shall only be replaced by the manufacturer or his service agent or a similar qualified person.

CAUTION

For safety reasons, please be aware that all modifications to the device are forbidden. If this device is operated in any way different to the ones described in this manual, the product may suffer damage and the warranty becomes void. Furthermore, any other operation may lead to short-circuits, burns, electric shocks, etc.

2. FEATURES

POWER SUPPLY

- AC100-240 V~, 50/60 Hz
- Power Consumption: 580 W maximum

OPTICS

- Beam aperture: 4° to 52°
- 140 mm frontal lens

LIGHT SOURCE

- 330 W LED white light engine
- Colour temperature output:
 - Stradale Profile S: 6,500 K
 - Stradale Profile TC: 6,000 K
- CRI:
 - Stradale Profile S: 70
 - Stradale Profile TC: 95

MOVEMENT

- Pan and tilt automatic repositioning
- Range: Infinite pan and tilt rotation

COLOURS

- Sophisticated CMY colour mixing
- Variable CTO
- Variable CRI channel
- Static colour wheel with 7 complimentary colours
- 1 circular multi-colour filter

GOBOS

- 9 indexable rotating gobo HD glass gobos
- Adjustable-speed rotating gobo
- 10 static HD glass gobos

FRAMING SYSTEM

- 4 individually shutter blades
- Rotation of the module: +/- 90°

IRIS DIAPHRAGM

- 15-blade iris diaphragm
- Range: 15% to 100% open

FROST

- 2 frost filters: one light, one heavy

PRISMS

- 2 combinable rotating and indexable prisms
- One 5-facet circular, one 4-facet linear

EFFECTS

- Focusable graphic animation effect-wheel
- Continuous rotation in both directions

DIMMER / STROBE

- Electronic dimmer from 0 to 100%
- Strobe effect: 1 to 25 flashes per second

HARDWARE FEATURES

- Graphic LCD display with flip function
- 5 menu buttons to set functions
- Integrated wireless LumenRadio™ receiver
- IP65 XLR 5 pin connectors
- IP65 RJ45 connectors
- IP65 powerCON TRUE1 TOP connectors

CONTROL

- DMX 512 protocol
- DMX-RDM compatible
- Stand-alone mode, local control panel
- ArtNet™ & sACN protocol
- 65/42 DMX channels

COOLING SYSTEM

- Advanced liquid cooling system
- Selectable ventilation user modes
- Excess temperature protection

HOUSING

- Skeleton made of aluminium
- Base in die-cast composite alloy
- Heatsinks in aluminium and copper

- Moulded covers ABS PC (V0 class)
- 4 handles on the yoke
- 4 heavy-duty feet
- IP65 protection rating (IP66 optional)

INSTALLATION

- 2 Omega ¼ turn brackets
- 4 ¼ turn mounting points
- Safety cable attachment point

OPERATING PARAMETERS

- Maximum permitted: 45°C (113°F)
- Minimum permitted: -20°C (-4°F)
- Minimum usage distance: 2 m (6.56 ft)

COMPLIANCE

- CE, UKCA, ETL

SIZE

- Product: 339 x 593 x 298 mm (l x h x d)
- Foam: 395 x 630 x 335 mm (l x h x d)

WEIGHT

- Product: 23.5 kg

3. FIXTURE OVERVIEW

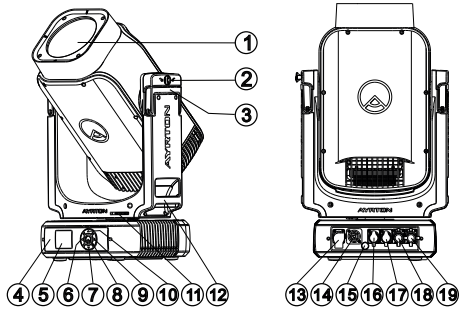

- | | | |
|----------------|------------------|--------------|
| 1. Front Lens | 8. Center-button | 15. Valve |
| 2. Tilt Lock | 9. Right-button | 16. RJ45 In |
| 3. Handle | 10. Up-button | 17. RJ45 Out |
| 4. NFC | 11. Pan Lock | 18. DMX In |
| 5. Display | 12. Handle | 19. DMX Out |
| 6. Left-button | 13. Power In | |
| 7. Down-button | 14. Power Out | |

4. DRAWINGS

4.1 › FIXTURE DIMENSION

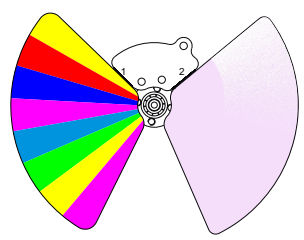
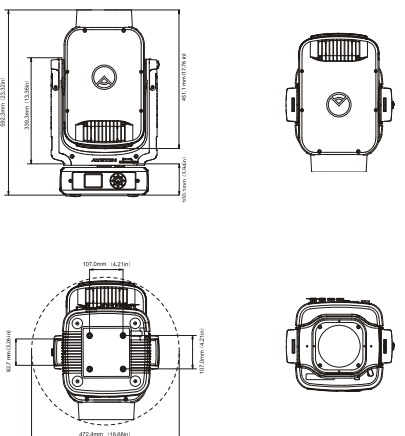
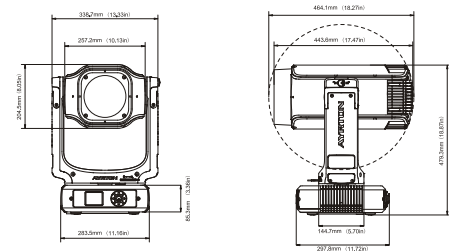

COLOUR WHEEL 2

1	Multi-colour filter	-
2	CTP	-

4.3 > ROTATING GOBO WHEEL

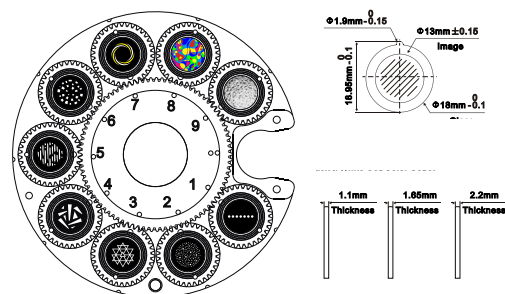

4.2 > COLOUR WHEEL

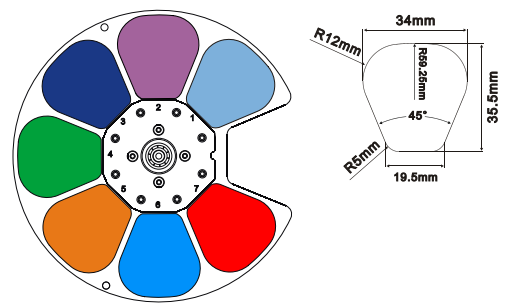

COLOUR WHEEL 1

1	CTB 1/4	GPG0100320
2	Magenta	GPG0100321
3	Congo Blue	GPG0100322
4	Green	GPG0100323
5	Orange	GPG0100324
6	Blue	GPG0100325
7	Red	GPG0100326

GOBO WHEEL 1

Rotating Gobo			
1	131	Dot Line 7	GPG0500963
2	075	Star Field	GPG0501011
3	018	Nested Triangle	GPG0500965
4	266	Breaking Glass	GPG0500966
5	278	Bread Stix	GPG0500967
6	070	Circle of Square	GPG0501012
7	112Y	Nested Rings Yellow	GPG0501013
8	042	CMY Liquid Effect	GPG0500970
9	601	Glass Animation	GPG0500921

4.4 > STATIC GOBO WHEEL

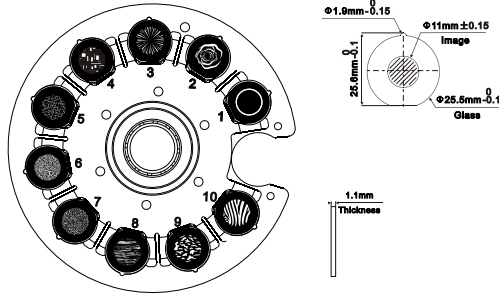

GOBO WHEEL 2

Static Gobo			
1	410	Conical Tunnel Effect	GPG0500971
2	049	Smoke Rings	GPG0501014
3	047	Fireworks	GPG0500973
4	066	Abstract Square	GPG0500974
5	081	Iron Filings	GPG0501015
6	041	Lost In The Brain	GPG0501016
7	101	Deep Forest	GPG0501017
8	105	Tree Bark	GPG0501018
9	103	Abstract Speck	GPG0500979
10	097	Zebra Stripes	GPG0500980

4.4 > ANIMATION DIMENSION

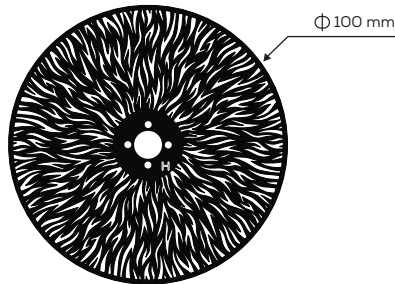

5. INSTALLATION INSTRUCTIONS

5.1 > RIGGING THE DEVICE

CAUTION

Please consider the respective national norms during the installation. The installation must only be carried out by a qualified person.

- The installation of the support structure has to be built and constructed in a way that it can hold 10 times the weight for 1 hour without any harming deformation.
- The installation must always be secured with a secondary safety

attachment, e.g. an appropriate safety rope.

- Never stand directly below the device when mounting, removing or servicing the fixture.
- The operator has to make sure the safety relating and machine technical installations are approved by an expert before taking the device into operation for the first time.
- These installations have to be approved by a skilled person once a year.
- Overhead mounting requires extensive experience, including amongst others calculating working load limits, installation material being used, and periodic safety inspection of all installation material and the device. If you lack these qualifications, do not attempt the installation yourself. Improper installation can result in bodily injury.

5.2 > RIGGING USING THE OMEGA BRACKETS

CAUTION

This step is very important to ensure safe rigging of the fixture.

- Fix the clamp to the bracket by tightening the M12 nut and bolt to the bracket through the $\Phi 13$ hole in the middle of the bracket.
- Insert the quick-lock fasteners of the first Omega holder into the respective holes on the bottom of the device. Tighten the quick lock fasteners fully clockwise.
- Install the second Omega holder.
- Pull the safe ty cable through the holes on the bottom of the base and over the trussing system or another suitable rigging point. Insert the end into the carabiner and tighten the safety screw.

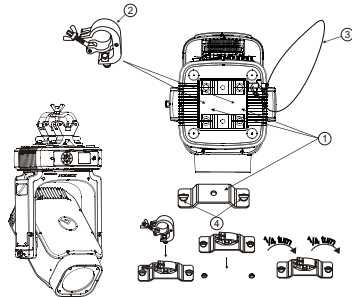

1. Omega bracket
2. Clamp
3. Safety rope
4. Quick-lock fastener

5.3 > RIGGING DRAWINGS

CAUTION

Overhead rigging requires extensive experience, including (but not limited to) calculating working load limits, specifying installation/rigging materials, and periodic safety inspection of all installation material as well as the device. If you lack these qualifications, do not attempt the rigging of this device yourself. Improper installation/rigging can result in serious bodily injury.

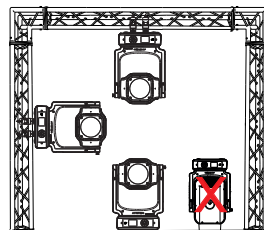

- **WARNING! Please ensure that under no circumstances should the lens be placed face down on any surface, including the ground, as this may cause damage to the lens or impair its optical performance.**
- Be sure this fixture is kept at least 0.1 m away from any flammable materials (decoration etc.).
- Always use and install a supplied safety cable as a safety measure to prevent accidental damage and/or injury in the event the clamp fails.
- Rig the projector high enough to provide clearance for people who may walk beneath the beam path or establishing a restricted access area that extends beyond the beam hazard distance.
- **WARNING! Please DO NOT let other external intense lights to shine through the fixture front lens, it may cause significant internal damages!**
- When install fixture outdoor at day time (with power off), please make sure that the fixture front lens is NOT facing the sun.
- When use fixture outdoor at day time (with power on), please avoid fixture front lens facing the sun.
- When fixture is on standby outdoor at day time (with power ON and no DMX signal), please make sure the "sun protection" mode is ON (default).

6. DMX-512 CONTROL CONNECTION

Connect the provided male side of the XLR cable to the female XLR output of your controller and the female side of the XLR cable to the male XLR input of the device. You can connect multiple devices together in a serial fashion. The cable needed should be two core, screened cable with XLR input and output connectors. Please refer to the diagram below.

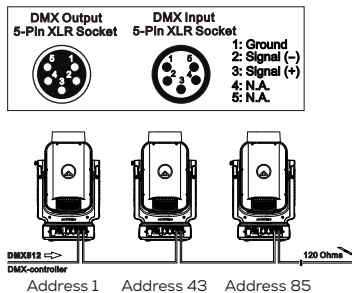

7. DMX-512 CONNECTION WITH DMX TERMINATOR

For installations where the DMX cable has to run over a long distance or is in an electrically noisy environment, such as in a discotheque, it is recommended to use a DMX terminator. This helps in preventing corruption of the digital control signal caused by electrical noise. The DMX terminator is an XLR plug with a 120 Ω resistor connected between pins 2 and 3, which is then plugged into the output (female) XLR socket of the last fixture in the chain. Please see illustrations below.

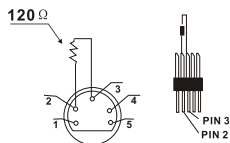

8. DEVICE DMX START ADDRESS SELECTION

All fixtures should be given a DMX starting address when using a DMX signal, so that the correct fixture responds to the

correct control signals. This digital starting address is the channel number from which the fixture starts to "listen" to the digital control information sent out from the DMX controller. The allocation of this starting address is achieved by setting the correct address number on the display located on the base of the device.

You can set the same starting address for all fixtures or a group of fixtures, or set different addresses for each fixture individually.

If you set the same address on all devices, all the devices will start to "listen to" the same control signal from the same channel number. In other words, changing the settings of one channel will affect all the fixtures simultaneously.

If you set a different address, each unit will start to "listen to" the channel number you have set, based on the quantity of control channels of the unit. That means changing the settings of one channel will affect only the selected device.

In the case of the LED moving head, in 42 channel mode, you should set the starting address of the first unit to 1, the second unit to 43 (42 + 1), the third unit to 85 (42 + 43), and so on.

9. OPERATING INSTRUCTIONS OF THE INTERNAL DMX WIRELESS SYSTEM

9.1 > EQUIPMENTS

DMX 512 controller, wireless transmitter, and the fixtures with wireless receiver.

9.2 > MESSAGE FROM THE LED INDICATOR

- Rapid flashing red/Green: Logging in to a transmitter.
- Slow flashing Red/Green: Logged on a transmitter and the DMX line is idle (No DMX is connected to transmitter).
- Solid Green: Logged on to a transmitter and receiving DMX data.
- Solid Red: Not logged on to a transmitter (free).

9.3 > WDMX IN THE MENU OF THE FIXTURE

On a fixture installed with wireless system, in order to switch between wireless control system and traditional DMX control (with cable), a new menu WDMX is added to the display board.

ON (Activate WDMX)

- When the fixture is on power and the WDMX is activated to ON status, but did not connect to the controller and did not log in to the transmitter, the fixture will search for the DMX signal source. If the fixture is connected to the DMX controller it can be controlled by DMX controller; if it is log in to the wireless transmitter, it can be controlled by the Transmitter.
- When the fixture is power off, and the WDMX is in ON status, if the fixture is connected to DMX controller. After the fixture is power on, it can be controlled only by the DMX controller which connected. The fixture can log in the wireless transmitter, and receive only radio signal from transmitter but not DMX from the transmitter.

OFF (De-activate WDMX)

- In this status, wireless system is not activated, so the fixture can not log in to the transmitter.

REST (Reset WDMX memory)

- Can remove the fixture from the connection with the transmitter, the fixture become free and ready to log in any transmitter.

9.4 > SET UP THE WIRELESS SYSTEM

- Connect the transmitter with the DMX controller.
- To make the fixture installed with wireless receiver log in to the transmitter.
 - Initially the indicator on the receiver fixture should be in Solid red.
 - Press and hold the configuration button on transmitter for less

than 3 seconds the red/green LEDs on the transmitter and the receiver fixture will flash rapidly for about 5~10 seconds while the system goes through its setup procedure.

- Once the receiver fixture is logged in to the transmitter (T1), the fixture with wireless receiver will keep the memory, even if restart the power, this unit will log in the transmitter (T1) automatically.
- Use the DMX 512 to control the fixture.

9.5 › REMOVE THE RECEIVERS FROM TRANSMITTER (T1) AND TO LOG IN TO ANOTHER TRANSMITTER (T2)

Case 1: Remove a receiver

- On the control board of the fixture, enter menu to activated the function of REST.
- The LED for wireless on the fixture should turn to Solid red; the receiver can log out from the transmitter (T1).
- Press the configuration button on transmitter (T2) for less than 3 second, then the fixture will start to connect with the transmitter (T2).







Case 2: Remove all receivers from a transmitter (T1) to log in to T2

- Press and hold the configuration button on the T1 as least 5 seconds, can clear the connection with all the fixtures.
- All the red/green LEDs on the receiver fixtures will turn to Solid red to indicate that the receivers are unassigned and removed from the transmitter (T1).

PS:

- Please log the receivers out from the transmitter after every job so that the receivers are in free un assigned state and ready to be assigned to a transmitter.
- Do not connect the fixture which is under the communication of wireless system to the DMX controller, otherwise it will cause interference from the DMX controller.

10. DISPLAY

- The Display offers several features: you can set the starting address run the pre-programmed program or reset the device.
- The main menu is accessed by double clicking  button until the display starts flashing.
- Browse through the menu by pressing , ,  or  button.
- Press  for 2 seconds in order to exit menu, double click  to confirm. After accessing the edit mode, the unit will automatically exit to the main menu after 15 seconds from the last button press.
- When the unit is powered on if no data signal is connected after 1 minute then the display will switch off automatically.

DEFAULT SETTINGS SHADED

Address		
Address	DMX Address: 001-XXX Decimal Universe: XXXXX Net: XX Sub-Net: X Universe: X Signal: DMX/WDMX/Art-Net/sACN	DMX Address Decimal Universe Net Sub-Net Universe Signal
Mode		
User Mode	Extend Mode Stand Mode	User's mode to change channel numbers

Options			
Status	No DMX Mode	Close/Hold/Auto	Auto run if no DMX
	Sun Protection	ON/OFF	Sun Protection
	Pan Reverse	ON/OFF	Pan Reverse movement
	Tilt Reverse	ON/OFF	Tilt Reverse movement
	Pan Degree	630/360/360 SC	Pan Degree Select
	Tilt Degree	270/540/360 SC	Tilt Degree Select
	Feedback	ON/OFF	Movement Feedback
	Encoder Select	Photoelectric/Magnet	Encoder Select
	Init PAN	ON/OFF	Init PAN
	Init TILT	ON/OFF	Init TILT
	Prerig INIT	ON/OFF	Prerig INIT
	Reset Mode	Fast/All Rot Gobos	Reset Mode
	Pan/Tilt Spd	Fast/Medium/Slow/FS Mode/Tracking 360	Movement Speed
	CMY Spd	Fast/Medium/Slow	CMY Spd
	CMY Path	Shotted/Spinout	CMY Path
	Zoom/Focus Spd	Fast/Medium/Slow	Zoom/Focus Spd
	Framing Mode	Constant/OFF/Constant ON	Framing Mode
	Reset LED Fade	ON/OFF	Reset LED Fade
	Hibernation	OFF 01M-99M	Stand by Mode
	DMX Output	ON/OFF	DMX Output
Data Collect	Agree/Disagree	Data Collect	
4G/WiFi	4G/WiFi	4G/WiFi	
WiFi Info	No/Yes	WiFi Information	
Service PIN	Service PIN	Password = XXX	Service Password="050"
	Set IP	xxx.xxx.xxx.xxx	Set IP
	Set Mask IP	xxx.xxx.xxx.xxx	Set Mask IP
	Reset From Mac	ON/OFF	Reset From Mac
	DHCP	ON/OFF	DHCP
	lot Lock Enable	ON/OFF	lot Lock Enable
	Cross Load SW	ON/OFF	Cross Load SW
Clr Error Info	ON/OFF	Clr LED Timer	
Fans Control	Fans Speed	Auto Stage Silence Super Silence	Fans Speed select
	Constant Fans	ON/OFF	Constant Fans
Disp.Setting	Shutoff Time	02-60m 05m	Display shutoff time
	Flip Display	ON/OFF	Reverse 180 degree
	Key Lock	ON/OFF	Key Lock
	DispFlash	ON/OFF	DispFlash
Temp. C/F	Celsius		Temperature switch
	Fahrenheit		between °C / °F
Initial Pos.	PAN=XXX		Initial effect position
Wireless DMX	Activate WDMX		Activate WDMX
	Rest WDMX		Rest WDMX
Dim Curve	Square Law		
	Linear Linear Low		
Refresh Select	12K		Refresh Select
	2.4K		
	16K		
	25K		
Defog	OFF		Defog off
	Auto ON		Defog auto Defog on
Gobo Correction	OFF/ON	Gobo Correction	
Reset P/T Fade	ON/OFF	Reset P/T Fade	
Frost (Progressive)	ON/OFF	Frost (Progressive)	

Options			
Trigger	DMX Value Disp. Set to Follower Auto Program	PAN..... Follower 1, Follower 2, Follower 3 Leader/Alone	DMX Value Disp. Set to Follower Auto Program
Reset Default	ON/OFF		Restore factory set.
Reset User	Address	DMX address: 001-XXX Decimal Universe: XXXX Net: XX Sub-Net: X Universe: X Signal: DMX/WDMX/Art-Net/sACN Encoder Select Photoelectric/Magnet	DMX Address Decimal Universe Net Sub-Net Universe Signal Encoder Select
	Mode	Extend Mode Stand Mode	User's mode to change channel numbers
	Fans Speed	Auto Stage Silence Super Silence	Fans Speed select
	Constant Fans	ON/OFF	Constant Fans
Info			
Time Info.	Current Time Ttl Life Hrs Last Run Hrs LED Hours Timer PIN Clr Last Run		XXXX(Hours) XXXX(Hours) XXXX(Hours) XXXX(Hours) Password = XXX ON/OFF
Temp. Info	Head Temp.		XXX'C/F
Humidity	x%		Humidity
Encoder Info	xxx		Encoder Info
Fan Info.	xxxx RPM		Fan information
LED Type	xxx		LED Type
Software Ver	V1.0.....		Software version
Signal Quality	xxx		Signal Quality Information
Network	IP, Mask, Mac		Network
Error Info.	Error Record 1 :		Error Info.
SN	Product: xxxxx... LED: xxxxx...		SN
RDM UID	UID: xxx-xxxxxxx		RDM UID
Test			
Home	All Pan&Tilt Colour Gobo Other		All Pan&Tilt Colour Gobo Other
Test Channel	PAN		Test function
Manual Ctrl.	PAN =XXX :		Fine adjustment of the lamp

Test			
Calibration	-Password- PAN :		Password "050" Calibrate and adjust the effects to standard/right position
Cmy Comp	Service PIN C M :		Cmy Comp
Magn Auto Cal	-Password- Calibration		Magn Auto Cal
Gobo Replace	Gobo Wheel 1 Gobo Wheel 2		Gobo Replace
Preset			
Select Prog.	Prog. Part 1 = Program 1 ~ 10 Program 1 Prog. Part 2 = Program 1 ~ 10 Program 2 Prog. Part 3 = Program 1 ~ 10 Program 3		Select programs to be run
Edit Prog.	Program 1 : Program 10	Program Test Step 01=SCxxx Step 64=SCxxx	Testing program Program in loop Save and exit
Edit Scenes	Edit Scene 001 ~ Edit Scene 250	Pan,Tilt..... --Fade Time-- --Scene Time-- Input By Outside	Save and automatically return manual scenes edit
Scenes Input	XX-XX		Scenes Input

10.1 > ADDRESS

10.1.1. Address

With this function, you can adjust the DMX address, the Universe and the selection of the control signal

10.2 > MODE

10.2.1. User Mode

With this function, you can choose user defined channel orders.

10.3 > OPTIONS

10.3.1. Status

No DMX Status

With this function, you can choose the unit behavior in case no signal is detected between Close (all dmx value to 0), Hold (keep the last dmx value), and Auto (start auto mode).

Sun Protection

When this function is activated, the unit will automatically tilt down its head toward the ground when no signal is detected.

Pan Reverse

With this function you can reverse the Pan-movement.

Tilt Reverse

With this function, you can reverse the Tilt-movement.

Pan Degree

With this function, you can select the total Pan degree range between 630, 540 or 360SC.

Tilt Degree

With this function, you can select the total Tilt degree range between 270, 540 or 360SC.

360SC

This mode limits the total range of movement (pan or tilt) to a maximum of 360°. Since the fixture supports continuous rotation, it automatically selects the shortcut (SC) or fastest path between two position commands. For example, if transitioning from a

pan position of 359° to 4°, the fixture will take the direct route, preventing unnecessary flips or spinouts.

Feedback

This function allows you to activate or deactivate the automatic repositioning of the Pan & Tilt in case of an accidental/manual move of the yoke.

Encoder Select

This option allows you to choose the encoder for unit positioning (pan and tilt):

- **Magnetic Encoder:** Uses an Absolute encoder for faster resets, eliminating the need for a full reset spin.
- **Photoelectric Encoder:** Utilises a light sensor and optical encoder, requiring an end-stop rotation for calibration, resulting in a slower reset.

Init PAN

This function allows you to deactivate the Pan movement.

Init TILT

This function allows you to deactivate the Tilt movement.

Prerig INIT

Allows you to activate a special init process: Pan init then Tilt init process when unit is used in prerig trusses

Reset Mode

This function allows you to choose the reset process for the gobo.

- **Fast:** The fixture only check the direction of the first gobo
- **All Rot Gobo:** The fixture is checking all the position of each gobo to make sure all the gobo are in the same position (Useful if using a custom Gobo)

Pan/Tilt Spd

With this function, you can select Pan & Tilt speed from "Fast", "Medium", "Slow", "FS Mode", "Tracking 360".

CMY Spd

With this function, you can select CMY speed from "Fast", "Medium", "Slow".

CMY Path

This function allows you to choose between Shortcut and Spinout modes, which determine how the colour filter reacts to a command.

Shortcut

The colour filter takes the shortest route to the target colour in snap command (Os). The shortest route could take a filter from 70% saturation past 100% saturation to get to open white. A fade time above Os will cause the filter to behave like spinout mode.

Spinout

The colour filter transitions smoothly by either increasing or decreasing saturation but never passes through open white to reach another colour.

Zoom/Focus Spd

With this function, you can select Zoom/Focus speed from "Fast", "Slow", "Medium"

Reset LED Fade

Allows the Light output to fade out and in during the reset process

Hibernation

The device and stepper motors will be powered off if the unit stays without DMX signal for the User defined times (in Minutes). The fixture will perform a reset sequence once DMX is back.

DMX Output

With this function, the unit can transmit the signal received via WDMX or ArtNet/sACN through the DMX output.

Data Collect

With this Function, you can activate the collection of data information for the IoT. (The optional board is needed to use this option).

4G/Wifi

With this function, you can select between Wifi or 4G.

Wifi Info

With this function you can see the status of the Wifi.

10.3.2. Service PIN

Password

The Password for this function is "050".

Set IP

This function allows you to set the IP of the Unit.

Set Mask IP

This function allows you to set the IP Mask of the Unit.

Reset From Mac

This function allows you to enable or disable the DHCP.

DHCP

This function allows you to enable or disable the DHCP

lot Lock Enable

Enable or Disable the lot Lock function (The optional board is needed to use this option)

Cross Load SW

This function allows you to upload the current SW version to other units using a DMX connection. Do not disconnect the units before the process is complete.

Clr Error Info

This function allows you to clear the error info list

10.3.3. Fans Control

Fans Speed

With this function, you can set the fans speed. Settings are Auto, Stage, Silence, and Super Silence.

- **Auto:** The LED module delivers high output and the fans ramp up and down depending on the ambient temperature and the temperature of the LED module itself.
- **Stage:** The LED module delivers full output and the fans remain at full speed regardless of the temperature of the LED module.
- **Silence:** The LED module is limited to medium output and the fans rotate at a slower speed.
- **Super Silence:** The LED module is limited to a lower output and the fans rotate at the slowest speed.

For specific output details, refer to photometry document.

Constant Fans

Enables you to set the fans to run continuously, even when the LED is off.

10.3.4. Disp. Setting

Shut off Time

With this function, you can select the delay before the LCD display turns off. Choose between 2 to 60 minutes. The default is 5 minutes.

Flip Display

With this function you can rotate the display by 180° (when the unit is rigged)

Key Lock

With this function you can activate the automatic key lock function. If this function is activated, the keys will be locked automatically after exiting the edit mode for 15 seconds. Keeping press the <MODE/ESC> key for 3 seconds if you do not need this function.

DispFlash

With this function activated, display will flash if no signal is detected.

10.3.5 Temperature C/F

With this function you can display the temperature in Celsius or Fahrenheit.

10.3.6. Initial Pos.

With this function you can display initial effect position.

10.3.7. Wireless

From factory, this projector is prepared for wireless data transmission (W-DMX). If you wish to de-activate W-DMX control, you can select the function "De-activate WDMX" by turning the encoder. With the function "Rest", you can log out the projector from the wireless sender.

10.3.8. Dim Curve

With this function you can select the Dimmer Curve.



10.3.9. Refresh Select

With this function you can select the PWM rate.

- 1.2K & 2.4: provides superior dimming quality, especially for smooth fadeouts at lower levels
- 16K & 25K: are ideal for broadcast use

10.3.10. Defog

This function allows you to set the defog mode as follows:

- ON: Activates the defog fan (excluding the LED module cooling fans), sets the dimmer to full, and zoom to minimum. This function should only be used when necessary.
- AUTO: Activates the defog fan (excluding the LED module cooling fans) when temperature and humidity reach a certain level. Zoom and dimmer are not affected.
- OFF: No defogging actions are performed, the defog fan will not rotate and the heaters are turned off.

If ON or AUTO are selected, the heater plate will turn on when the unit is powered on. The Heater will turn on and off as necessary to maintain a constant internal temperature of 45 °C.

10.3.11. Gobo Correction

This function allows you to enable or disable the Gobo Correction. The Unit will automatically insert a correction filter when a glass gobo is inserted.

10.3.12. Reset P/T Fade

This function allows you to choose the reset speed of the pan/tilt motors to avoid fast movement.

10.3.13. Frost (Progressive)

This function allows you to enable or disable the progressive insertion of the frost.

10.3.14. Trigger

DMX Value Disp.

With this function you can display the DMX 512 value of each channel. The display automatically shows the channel with a value changing.

Set to Follower

With this function, you can define the device as follower

- Double click the center button to access main menu.
- Tap the <Up/Down> button until "OptionsOptions" is displayed.
- Double click the center button to access Options" Tap the <Up/Down> button to select "Trigger".
- Double click the center button to access " menu Tap the <Up/Down> button to select "Set To Follower"
- Double click the center button to access "Set To The display will show "Follower1", "Follower2", "Follower3".
- Double click the center button to confirm or long press the center button to return to the main menu.

Auto Program

With this function, you can run the internal program. You can select the desired program under "Select program". You can set the number of steps under "Edit program". You can edit the individual scenes under "Edit scenes". With this function, you can run the individual scenes either automatically, i.e. with the adjusted Step-Time.

10.3.15. Reset Default

With this function, you can select restore factory set for ON or OFF. the default is OFF.

10.3.16. Reset User

With this function, you can define the following "restore user" values:

- Address
- Mode
- Fans Speed
- Constant Fans

10.4 > INFO

10.4.1. Time Info.

Current Time

With this function, you can display the temporary running time of the device from the last power on. The display shows "XXXX". "XXXX" stands for the number of hours. The counter is reset after turning the device off.

Ttl Life Hrs

With this function, you can display the running time of the device. The display shows "XXXX". "XXXX" stands for the number of hours.

Last Run Hrs

With this function, you can display last the running time of the device. The display shows "XXXX". "XXXX" stands for the number of hours.

LED Hours

With this function, you can display the time of LED. The display shows "XXXX". "XXXX" stands for the time of LED.

Timer PIN

With this function, you can display the timer password.

Clr Last Run

With this function, you can clear last run time of the fixture. The display shows "ON" or "OFF". Press "Enter" to confirm.

10.4.2. Temp.Info

With this function you can display the different temperature of the fixture.

- L: Light engine
- B: Base
- H: Head

10.4.3. Humidity

With this function you can display all the different humidity values available in the fixture

- B: Base
- H: Head

10.4.4. Encoder Info.

With this function, you can display the encoder values.

10.4.5. Fan Info.

With this function, you can display all the fan speed values available in the unit.

10.4.6. LED Type

With this function, you can display the Led Type, S/TC/ST

10.4.7. Software Ver

With this function, you can display the software version of the device.

10.4.8. Signal Quality

When IOT Board is connected, this menu shows the signal quality (Wifi/4G).

10.4.9. Network

With this function, you can display the Network information.

10.4.10. Error Info

With this function, you can read the error record of the Unit.

10.4.11. SN

With this function, you can display the serial number of the Unit.

10.4.12. RDM UID

With this function, you can display the RDM UID of the Unit.

10.5 > TEST

10.5.1. Home

With this function you can reset the device. You can select which functions you want to reset by using the submenu.

10.5.2. Test Channel

With this function you can test each channel's function to ensure correct operation.

10.5.3. Manual Control

Allows you to manually control each feature of the unit

10.5.4. Calibration

With this function, you can calibrate and adjust the effect wheels to their correct positions. The password of calibrate values is 050.

10.5.5. CMY Comp

With this function, you can calibrate and adjust the CMY compensation values.

10.5.6. Magn Auto Cal

This Function allow you to Automatically calibrate the Absolute encoder using the Photoelectric one.

10.5.8. Gobo Replace

This function allows you to select the gobo you want to replace. The chosen gobo will be rotated into position, making it easy to swap out.

10.6 > PRESET

Run the auto program: A leader fixture can output to three different program signals to the follower fixture to operate. It means the host will send cyclically in the following orders (The host will keep operating the program of Part 1). Then the follower fixture will make the selectively receiving according to its own set.



- If the follower fixture chooses Run For Follower 1 from the menu of 1-3, then it will receive the part 1's automatic program from link, in the same way, when the follower fixture chooses Run For Follower 2, then it will receive the part 2's automatic program from link.
- Enter the menu of 1-3 Function Mode---Set To Follower. Here to set machine operate which part of the program during the host-follower connection
- Enter the menu of 1-4, 1-5 Function Mode---Set To Leader
- Enter the menu of 8-1 Edit Program---Auto Program Part1. The host outputs three groups driven program---Part1, Part2, Part3 (Part1 program runs the same effect as the host)
- Enter the menu of 8-2 Edit Program---Edit Program. Edit the program's connection, connect the scene in order
- The editor of the scene, there are as many as 250 scenario editors, and every scene can have a program connection of 10.

Note:

Part 2, Part 3 repeat in accordance with the Part1's repeat. For example: When Part 1 uses Program 2, Part 2 uses Program 4, Part 3 uses Program 6, Assume: Program 2 includes scene of 10, 11, 12, 13. Program 4 includes scene of 8, 9, 10; Program 6 includes scene of 12, 13, 14, 15. Then it will run as below.

Example:

Part 1:



Part 2:



Part 3:



10.7 > SHORTCUT MENU

10.7.1. Flip display

With this function you can rotate the display by 180° (when the unit is rigged)

10.7.2. Restore Factory

With this function, you can restore default setting (highlighted value in the above chart).

10.7.3. Restore User

With this function, you can restore User settings (Setting can be edit under Options/Reset User Set).

10.7.4. Rst DMX addr 1

With this function you can only set the address to 1.

10.7.5. Product SN

With this function, you can display the serial number of the Unit.

10.7.6. LED SN

With this function, you can display the serial number of the LED.

10.7.7. RDM UID

With this function, you can display the RDM UID of the Unit (Also QRCode)

10.7.8. Pressure

Under this menu, you can manage the pressure of the Unit :

- **Pressure Test :** Under this menu you can Run the Pressure test
- **Test Result:** Under this menu you can display the result of the last pressure test
- **Head/Base Pres:** Under this menu you can display the value of the Head and Base Pressure

11. NFC

When the fixture is powered on, you can use a NFC smartphone installed with the Ayrton App to scan the NFC tag area of the fixture to read some of the information or settings inside the display menu, such as product name, software version, UID, DMX Start Address, Universe, User Mode, Options, Information, etc. You can also change some of the settings and push to write inside the fixture menu.

When the fixture is not powered on, you can still use the App to read the NFC info and write the settings into the NFC tag, the written data will be automatically synchronized into the fixture menu at next time the fixture is powered on.

Link to download the application: <https://qrstud.io/ayrtonnfc>

Note:

- *Before using, make sure there is NFC function on your smartphone and it is activated, Download and install the Ayrton App;*
- *The NFC tag on the fixture is right under the LCD window;*
- *The NFC reader area vary on different smartphones, identify the correct area on your smartphone before scanning the NFC tag on the fixture;*
- *When scanning, make sure the NFC reader area of your smartphone close enough to the LCD window and hold still the smartphone for 3 seconds until reading successfully*

12. DMX PROTOCOL

Scan the QR code on the cover page to download the DMX CHART.

13. ERROR MESSAGES

When you turn on the device, it will first perform a reset. The display may show "Err channel is XX" should there be problems with one or more functions. "XX" stands for channel 1, 2, 3, 4, 5, 6 etc whose sensor has encountered a problem. For example, when the display shows "Err channel is Pan movement", it means there is an error on channel 1. If there are errors on channel 1, channel 3, channel 6 at the same time, you may see the error message, "Err channel is Pan movement", "Err channel is Tilt movement", "Err channel is Shutter", flash twice, and then the device will generate a second reset. If the

error messages persist after performing a reset more than twice, the channels which have errors may not work properly however, all other functions can work as usual. Please contact your dealer or manufacturer for service. Self repair is not allowed.

PAN- movement Er

(PAN- yoke movement error) This message will appear after the reset of the fixture if the yoke's magnetic-indexing circuit malfunction (Optical Sensor or Magnetic Sensor fails) or the stepper motor is defective (or its driving IC on the main PCB). The PAN-movement is not located in the default position after the reset.

TILT- movement Er

(TILT- head movement error) This message will appear after the reset of the fixture if the head's magnetic-indexing circuit malfunctions ((Optical Sensor or Magnetic Sensor fails)) or the stepper motor is defective (or its driving IC on the main PCB). The TILT-movement is not located in the default position after the reset.

Zoom wheel Er

(Zoom wheel error) This message will appear after the reset of the fixture if the head's magnetic-indexing circuit malfunctions (Optical Sensor or Magnetic Sensor fails) or the stepper motor is defective (or its driving IC on the main PCB). The Zoom -movement is not located in the default position after the reset.

Focus wheel Er

(Focus wheel error) This message will appear after the reset of the fixture if the head's magnetic-indexing circuit malfunctions (Optical Sensor or Magnetic Sensor fails) or the stepper motor is defective (or its driving IC on the main PCB). The Focus -movement is not located in the default position after the reset.

Colour wheel Er

(Colour wheel- error) This message will appear after the reset of the fixture if the head's magnetic-indexing circuit malfunctions (sensor failed or magnet missing) or the stepper motor is defective (or its driving IC on the main PCB). The Colour - movement is not located in the default position after the reset.

Cyan Colour wheel Er

(Cyan Colour wheel- error) This message will appear after the reset of the fixture if the head's magnetic-indexing circuit malfunctions (sensor failed or magnet missing) or the stepper motor is defective (or its driving IC on the main PCB). The CMY -movement is not located in the default position after the reset.

Magenta Colour wheel Er

(Magenta Colour wheel- error) This message will appear after the reset of the fixture if the head's magnetic-indexing circuit malfunctions (sensor failed or magnet missing) or the stepper motor is defective (or its driving IC on the main PCB). The CMY -movement is not located in the default position after the reset.

Yellow Colour wheel Er

(Yellow Colour wheel- error) This message will appear after the reset of the fixture if the head's magnetic-indexing circuit malfunctions (sensor failed or magnet missing) or the stepper motor is defective (or its driving IC on the main PCB). The CMY -movement is not located in the default position after the reset.

CTO Colour wheel Er

(CTO Colour wheel- error) This message will appear after the reset of the fixture if the head's magnetic-indexing circuit malfunctions (sensor failed or magnet missing) or the stepper motor is defective (or its driving IC on the main PCB). The CTO -movement is not located in the default position after the reset.

Rot_Gobo wheel Er

(Rot_Gobo wheel - error) This message will appear after the reset of the fixture if the head's magnetic-indexing circuit malfunctions

(sensor failed or magnet missing) or the stepper motor is defective (or its driving IC on the main PCB). The Rot_Gobo1 - movement is not located in the default position after the reset.

Fix_Gobo wheel Er

(Fix_Gobo wheel - error) This message will appear after the reset of the fixture if the head's magnetic-indexing circuit malfunctions (sensor failed or magnet missing) or the stepper motor is defective (or its driving IC on the main PCB). The Fix_Gobo - movement is not located in the default position after the reset.

Animation wheel Er

(Animation wheel - error) This message will appear after the reset of the fixture if the head's magnetic-indexing circuit malfunctions (sensor failed or magnet missing) or the stepper motor is defective (or its driving IC on the main PCB). The Animation - movement is not located in the default position after the reset.

Iris wheel Er

(Iris wheel - error) This message will appear after the reset of the fixture if the head's magnetic-indexing circuit malfunctions (sensor failed or magnet missing) or the stepper motor is defective (or its driving IC on the main PCB). The Iris - movement is not located in the default position after the reset.

Prism 1 wheel Er

(Prism 1 wheel- error) This message will appear after the reset of the fixture if the head's magnetic-indexing circuit malfunctions (sensor failed or magnet missing) or the stepper motor is defective (or its driving IC on the main PCB). The Prism 1 - movement is not located in the default position after the reset.

Prism 2 wheel Er

(Prism 2 wheel- error) This message will appear after the reset of the fixture if the head's magnetic-indexing circuit malfunctions (sensor failed or magnet missing) or the stepper motor is defective (or its driving IC on the main PCB). The Prism 2 - movement is not located in the default position after the reset.

Blade 1 wheel Er

(Blade 1 wheel- error) This message will appear after the reset of the fixture if the head's magnetic-indexing circuit malfunctions (sensor failed or magnet missing) or the stepper motor is defective (or its driving IC on the main PCB). The Blade 1 - movement is not located in the default position after the reset.

Blade 1_Rot wheel Er

(Blade 1_Rot wheel- error) This message will appear after the reset of the fixture if the head's magnetic-indexing circuit malfunctions (sensor failed or magnet missing) or the stepper motor is defective (or its driving IC on the main PCB). The Blade 1_Rot - movement is not located in the default position after the reset.

Blade 2 wheel Er

(Blade 2 wheel- error) This message will appear after the reset of the fixture if the head's magnetic-indexing circuit malfunctions (sensor failed or magnet missing) or the stepper motor is defective (or its driving IC on the main PCB). The Blade 2 - movement is not located in the default position after the reset.

Blade 2_Rot wheel Er

(Blade 2_Rot wheel- error) This message will appear after the reset of the fixture if the head's magnetic-indexing circuit malfunctions (sensor failed or magnet missing) or the stepper motor is defective (or its driving IC on the main PCB). The Blade 2_Rot - movement is not located in the default position after the reset.

Blade 3 wheel Er

(Blade 3 wheel- error) This message will appear after the reset of the fixture if the head's magnetic-indexing circuit malfunctions

(sensor failed or magnet missing) or the stepper motor is defective (or its driving IC on the main PCB). The Blade 3 - movement is not located in the default position after the reset.

Blade 3_Rot wheel Er

(Blade 3_Rot wheel- error) This message will appear after the reset of the fixture if the head's magnetic-indexing circuit malfunctions (sensor failed or magnet missing) or the stepper motor is defective (or its driving IC on the main PCB). The Blade 3_Rot - movement is not located in the default position after the reset.

Blade 4 wheel Er

(Blade 4 wheel- error) This message will appear after the reset of the fixture if the head's magnetic-indexing circuit malfunctions (sensor failed or magnet missing) or the stepper motor is defective (or its driving IC on the main PCB). The Blade 4 - movement is not located in the default position after the reset.

Blade 4_Rot wheel Er

(Blade 4_Rot wheel- error) This message will appear after the reset of the fixture if the head's magnetic-indexing circuit malfunctions (sensor failed or magnet missing) or the stepper motor is defective (or its driving IC on the main PCB). The Blade 4_Rot - movement is not located in the default position after the reset.

All_Blade_Rot wheel Er

(All_Blade_Rot wheel- error) This message will appear after the reset of the fixture if the head's magnetic-indexing circuit malfunctions (sensor failed or magnet missing) or the stepper motor is defective (or its driving IC on the main PCB). The All_Blade_Rot - movement is not located in the default position after the reset.

Frost 1 wheel Er

(Frost 1 wheel - error) This message will appear after the reset of the fixture if the head's magnetic-indexing circuit malfunctions (sensor failed or magnet missing) or the stepper motor is defective (or its driving IC on the main PCB). The Frost 1 - movement is not located in the default position after the reset.

Frost 2 wheel Er

(Frost 2 wheel - error) This message will appear after the reset of the fixture if the head's magnetic-indexing circuit malfunctions (sensor failed or magnet missing) or the stepper motor is defective (or its driving IC on the main PCB). The Frost 2 - movement is not located in the default position after the reset.

Animation_Rot wheel Er

(Animation_Rot wheel- error) This message will appear after the reset of the fixture if the head's magnetic-indexing circuit malfunctions (sensor failed or magnet missing) or the stepper motor is defective (or its driving IC on the main PCB). The Animation_Rot - movement is not located in the default position after the reset.

14. CLEANING AND MAINTENANCE

CAUTION



Disconnect from mains before starting maintenance operation



Do not place the fixture with its lens/glass facing any people while doing the IP test!



Never use alcohol or solvent to clean the lenses.



Always run an IP test using the Ayrton IP test kit following any maintenance operation! Failure to comply with this clause will void the warranty!



Ayrton IP Kit

The operator must follow strictly the vacuum and pressure setting values as below, or use the corresponding preset fixture menu to run the IP test. any overpressure operation may cause accidental damage or injury.

	Minimum value		Maximum value		Steady time (Hold time)
	Kpa	Psi	Kpa	Psi	
Vacuum	-30	-4.35	-35	5.08	10
Pressure	25	3.63	30	4.35	10

NOTE: When using external equipment to test air tightness, air can only be filled and extracted from the exhaust hole of the bottom base, not from the exhaust hole of the fixture head.

Once the covers removed and before set them back, check the cover gasket to avoid any leak due to gasket damage. Cross tightening the die-casting covers HEX screws at the right torque value.

Use a Torque Screwdriver set at 14 Kgf.cm (1.4 Nm) for metal cover or 7 Kgf.cm (0.7 Nm) for plastic cover.

The following points have to be considered during inspection:

- All screws for installing the devices or parts of the device have to be tightly connected and must not be corroded.
- There must not be any deformations to the housing, lenses, rigging and installation points (ceiling, suspension, trussing).
- Motorized parts must not show any signs of wear and must move smoothly without issue.
- The power supply cables must not show any damage, material fatigue or sediment.

Remove gobo module

- To remove gobo module, remove framing module first.
- Then move the gobo module towards the focus lens and remove.
- To remove the effects module, the open positions of the gobo wheels must be positioned towards the arm of the fixture.

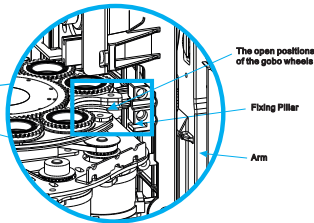
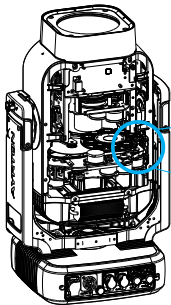

Checking and replacing the desiccant

The desiccant is used as humidity indication in the fixture. Dry desiccant is in blue colour, if it is saturated with water, its colour changes to light red. If the desiccant colour changes to pink, the desiccant is losing efficacy, it must be replaced.

CAUTION

Unplug the fixture from mains before checking or replacing desiccant!

Do not check or replace desiccant in a damp environment!

Further instructions depending on the installation location and usage have to be adhered to by a qualified installer and any safety concerns have to be removed. We recommend frequent cleaning of the device. Please use a moist, lint-free cloth. Never use alcohol or solvents. Please refer to the instructions under "Installation instructions".

Should you need any spare parts, please order genuine parts from your local dealer.



AYRTON

Digital Lighting

